

BLUE STAR

Power Systems Inc.

Gaseous Product Line

208-4160 Volt

NG425-01

60 Hz / 1800 RPM

425 kWe

Standby

Ratings

| | 208V | 240V | 480V | 600V | 4160V |
|------------------------|-------------|---------------|-------------|------------|------------|
| Phase | 3 | 3 | 3 | 3 | 3 |
| PF | 0.8 | 0.8 | 0.8 | 0.8 | 0.8 |
| Hz | 60 | 60 | 60 | 60 | 60 |
| Generator Model | 572RSL6425 | 572RSL6425 | 572RSL6425 | 572RSS4270 | 573FSM4354 |
| Connection | 12 LEAD WYE | 12 LEAD DELTA | 12 LEAD WYE | 4 LEAD WYE | 6 LEAD WYE |
| Standby | | | | | |
| kWe Nat (LP) | 425 (300) | 425 (300) | 425 (300) | 425 (300) | 425 (300) |
| AMPS Nat (LP) | 1476 (1042) | 1280 (903) | 640 (452) | 512 (361) | 74 (52) |
| Temp Rise | 105°C/40°C | 105°C/40°C | 105°C/40°C | 105°C/40°C | 105°C/40°C |

Standard Equipment

- | | | |
|--|--|---|
| <p>Engine</p> <ul style="list-style-type: none"> ▶ Radiator Cooled Unit Mounted (50°C) ▶ Blower Fan & Fan Drive ▶ Starter & Alternator ▶ Oil Pump & Filter ▶ Oil Drain Extension w/Valve ▶ Governor - Electronic Isochronous ▶ 24V Battery System & Cables ▶ Air Cleaner (Dry Single Stage) ▶ Flexible Fuel Connector ▶ EPA Certified ▶ MasterTrak Remote Monitoring System <p>Listing Certifications</p> <ul style="list-style-type: none"> ▶ UL 2200 Listed* ▶ cUL Listed* ▶ CSA Certified* ▶ Seismic Certified to IBC 2018 ▶ NFPA 110 Compliant | <p>Generator</p> <ul style="list-style-type: none"> ▶ Brushless Single Bearing ▶ Automatic Voltage Regulator ▶ ± .25% Voltage Regulation ▶ 4 Pole, Rotating Field ▶ 105°C Standby Temperature Rise ▶ 100% of Rated Load - One Step ▶ 5% Maximum Harmonic Content ▶ NEMA MG 1, IEEE and ANSI Standards Compliance for Temperature Rise | <p>Additional</p> <ul style="list-style-type: none"> ▶ Single Source Supplier ▶ Microprocessor Based Digital Control ▶ Interface Connection Box ▶ Control Panel Mounted in NEMA 12 Enclosure ▶ Base - Structural Steel ▶ Main Line Circuit Breaker Mounted & Wired* ▶ Catalyst / Silencer Mounted ▶ Battery Charger 24V 5Amp ▶ Jacket Water Heater -20°F 5000W 240V w/Isolation Valves ▶ Vibration Isolation Mounts (Pad Type) ▶ Radiator Duct Flange (OPU Only) ▶ 2YR / 2000HR Standby Warranty ▶ Standard Colors - White / Gray |
|--|--|---|

*Through 600VAC

Application Data

| Engine | | | |
|-----------------------|-------------------------------|--------------------------------------|---------------------------|
| Manufacturer: | Power Solutions International | Displacement - Cu. In. (lit): | 1,338 (21.9) |
| Model: | 21.9L | Bore - in. (cm) x Stroke - in. (cm): | 5.04 (12.8) x 5.59 (14.2) |
| Type: | 4-Cycle | Compression Ratio: | 10.5 : 1 |
| Aspiration: | Turbocharged, CAC | Rated RPM: | 1800 |
| Cylinder Arrangement: | 12 Cylinder Vee | Max HP Stby (kWm): | 684 (510) |

| Exhaust System | Standby |
|---|--------------|
| Gas Temp. (Stack): °F (°C) | 1,382 (750) |
| Gas Volume at Stack Temp: CFM (m³/min) | 2,995 (84.8) |
| Maximum Allowable Exhaust Restriction (Post Catalyst): in. H ₂ O (kPa) | 20.4 (5.10) |

| Cooling System | |
|---|--------------|
| Ambient Capacity of Radiator: °F (°C) | 122 (50.0) |
| Maximum Allowable Static Pressure on Rad. Exhaust: in. H ₂ O (kPa) | 0.50 (0.12) |
| Water Pump Flow Rate: GPM (lit/min) | 174 (659) |
| Heat Rejection to Coolant: BTUM (kW) | 25,760 (451) |
| Heat Rejection to CAC: BTUM (kW) | 6,080 (106) |
| Heat Radiated to Ambient: BTUM (kW) | 3,871 (67.7) |

| Air Requirements | |
|---|--|
| Aspirating: CFM (m³/min) | 968 (27.4) |
| Air Flow Required for Rad. Cooled Unit: CFM (m³/min) | 40,000 (1,132) |
| Air Flow Required for Heat Exchanger/Rem. Rad. CFM (m³/min) | Consult Factory For Remote Cooled Applications |

| Fuel Consumption | Natural Gas | LP |
|---|---------------|--------------|
| At 100% of Power Rating: ft ³ /hr (m ³ /hr) | 4,794 (136) | 1,401 (39.6) |
| At 75% of Power Rating: ft ³ /hr (m ³ /hr) | 3,762 (106.0) | 1,119 (31.7) |
| At 50% of Power Rating: ft ³ /hr (m ³ /hr) | 2,839 (80.3) | 860 (24.3) |
| Fuel Inlet Size: NPT | | 3.00" |
| Fuel Pressure Required: in. H ₂ O (kPa) | | 11.0 (2.75) |

| Fluids Capacity | |
|---|-------------|
| Total Oil System: gal (lit) | 10.6 (40.0) |
| Engine Jacket Water Capacity: gal (lit) | 13.8 (52.3) |
| System Coolant Capacity: gal (lit) | 60.2 (228) |

All calculations based on natural gas fuel.

Deration Factors: Temperature: Derate 1.5% Per 10°F Over 77°F Air Inlet Temperature | Altitude: Derate 2.5% Per 1,000 ft Over 1,200 ft

DGC-2020 Control Panel

Standard Features

- ▶ Digital Metering
- ▶ Engine Parameters
- ▶ Generator Protection Functions
- ▶ Engine Protection
- ▶ CAN Bus (J1939) ECU Communications
- ▶ Windows-Based Software
- ▶ Multilingual Capability
- ▶ Remote Communications to RDP-110 Remote Annunciator
- ▶ 16 Programmable Contact Inputs
- ▶ 15 Contact Outputs
- ▶ RS485 Communicator Interface
- ▶ UL Recognized, CSA Certified, CE Approved
- ▶ Event Recording
- ▶ IP 54 Front Panel Rating with Integrated Gasket
- ▶ NFPA 110 Level 1 Compatible



Weights / Dimensions / Sound Data

| | L x W x H | Weight lbs |
|----------------|-------------------|------------|
| OPU | 156 x 86 x 98 in | 10,875 |
| Level 1 | 156 x 86 x 110 in | 12,525 |
| Level 2 | 156 x 86 x 110 in | 12,650 |
| Level 3 | 228 x 86 x 110 in | 13,350 |

Please allow 6-12 inches for height of exhaust stack.

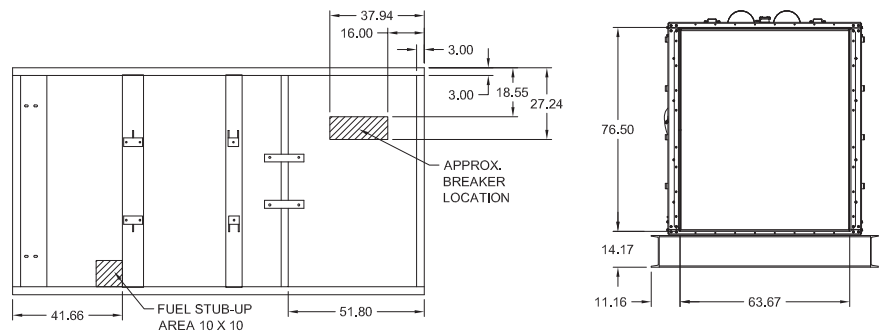

| | No Load | Full Load |
|----------------|---------|-----------|
| OPU | 84 dBA | 87 dBA |
| Level 1 | 82 dBA | 85 dBA |
| Level 2 | 77 dBA | 80 dBA |
| Level 3 | 72 dBA | 75 dBA |

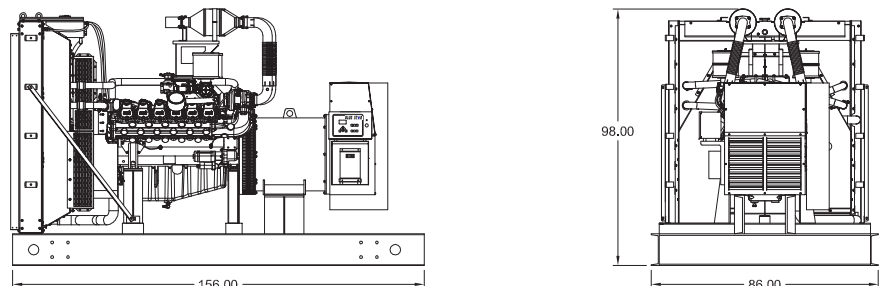

Drawings based on standard open power 480 volt standby generator. Lengths may vary with other voltages. Subject to change without notice. Sound data as measured at 23 feet (7 meters) in accordance with ISO 8528-10 at standby rating.

Gaseous Product Line

425 kW_e



Enclosures

Level 1 & 2 | Side View (Weather Proof)

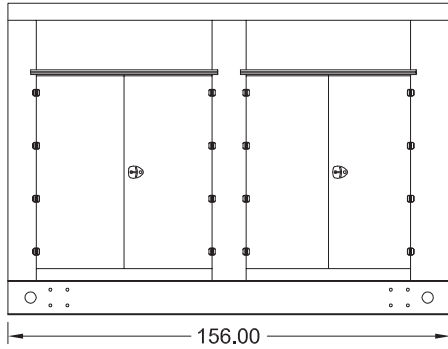

Level 3 | Side View (Sound Attenuated)

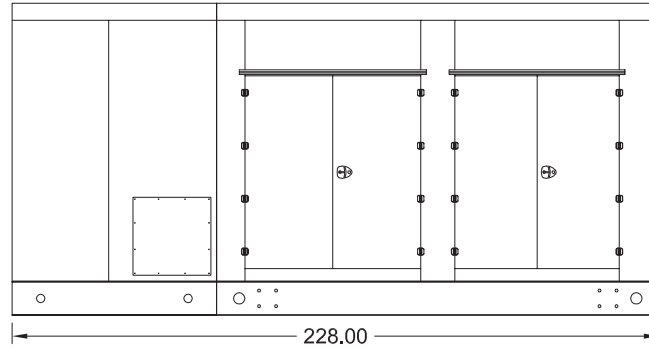

Level 1, 2 & 3 | Intake View

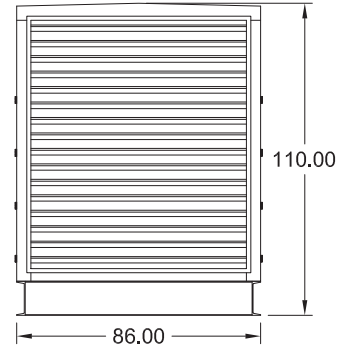

All enclosure models are 200 MPH wind rating certified in accordance with IBC2018 and ASCE/SEI 7-16 standards.

Level 2 & 3 enclosures include sound attenuation foam.

Level 3 enclosure includes frontal sound & exhaust hood.

*Enclosure height does not include exhaust stack.

All specification sheet dimensions are represented in inches.
Materials and specifications subject to change without notice.

Distributed By:

American Owned



American Made

Blue Star Power Systems, Inc.

2250 Carlson Drive

North Mankato, Minnesota 56003

Phone + 1 507 345 1776

bluestarps.com

quote.bluestarps.com

sales@bluestarps.com